

The Mix **LAINOX**

Project _____
 Item No. _____
 Quantity _____

BOILERLESS ELECTRIC COMBI STEAMER

VE 102 D

Direct steam combi steamer for dry heat, steam and combi cooking

CONSTRUCTION DETAILS

- 304 Stainless steel construction
- 304 Stainless steel cooking compartment with "trapezoid" shape, long radius rounded corners for a perfect cleaning (HACCP requirements) and fully water-proof
- 1 3/8" rock wool thermal insulation
- Thermal brake between the chamber and oven front panel to absorb steel expansion
- Double glazed door with air-space keeps glass cool
- Hinged inner door glass provides cleaning access
- Left or right door handle upon request (factory option)
- Adjustable door hinges
- Heat resistant, silicon rubber, push-fit door seal
- Door design includes condensation trough
- Hinged fan baffle cover for cleaning access
- Removable control panel for easy service of components
- Two water inlets
- Grouped utility connections
- External connection for meat probe
- Removable side racks with 2 3/4" distance between levels
- High quality components

ELECTRIC HEATING SYSTEM

- Chamber heating elements of armoured INCOLOY 800 type
- Energy Saving device for a reduced energy consumption



OPERATIONAL FUNCTIONS

- Control panel with manual controls
- Self-diagnosis at the start of the unit with faults display and alarm
- Cooking mode selector for hot air, steam, or combi
- Cook & Hold mode controlled by the meat probe or by the timer
- Low speed of ventilation enables a reduced heating suitable for slow cooking programs
- Autoreversing fan rotation
- Interchangeable meat probes with external socket
- Fast chamber cool down
- Automatic chamber cooling between a high temperature cycle and the next cycle featuring a lower temperature
- Manual humidifier
- Programmable and automatic chamber vent opening, to evacuate the excess of humidity
- Timed oven lights with halogen lamps positioned between the two glasses of the door
- Chamber clean program "CL"
- Automatic quenching of vapors into the oven drain
- Check of chamber steam saturation with automatic energy saving
- Easily accessible service program for:
 - PC board diagnosis
 - Check of internal probes
 - Check of cavity operating hours



VERSION D

Mechanical, with cooking timer and continuous cook system, autoreverse (automatic reverse of fan rotation), humidifier, oven chamber vent valve and lighting.

COOKING MODES

Convection 86°F – 572°F
 Steam 86°F – 266°F
 Combined convection-steam 86°F – 572°F
 Reheating with Autoclima 248°F – 284°F
 Core probe 86°F – 212°F

SAFETY FEATURES

- Chamber safety thermostat
- Chamber and boiler over pressure release
- Thermal protection of fan motor
- Door switch
- Displayed diagnostic
- Components cooling system

TECHNICAL DATA

- Voltage: 208-240/3/60
- Total electric power: 31 kW
- Hot air power: 30 kW
- Steam power: 30 kW
- Fan power: 1 kW

DIMENSIONS

- 46" x 35-1/4" x 43" h

CAPACITY

- 10 full size sheet pans or 20 hotel pans
- With side racks: distance between layers 2-3/4"
- With rack SG102: distance between layers 2-1/2"
- With plated meals rack PR102: 49 plates at 2-3/4" distance

OPTIONS

- Needle probe for vacuum packs **SE002**
- Two steps safety door handle mechanism
- Right hinged door
- Special and marine voltages
- Removable rack **SG102**
- Plated meals rack **PR102**
- Thermal cover **CP102**
- Trolleys **CR102**
- Fat filter **FX102**
- Stands **SR102 - SP102**
- Hand shower **LD25**
- Connection for energy saving system SN

APPROVALS



VE 102 D

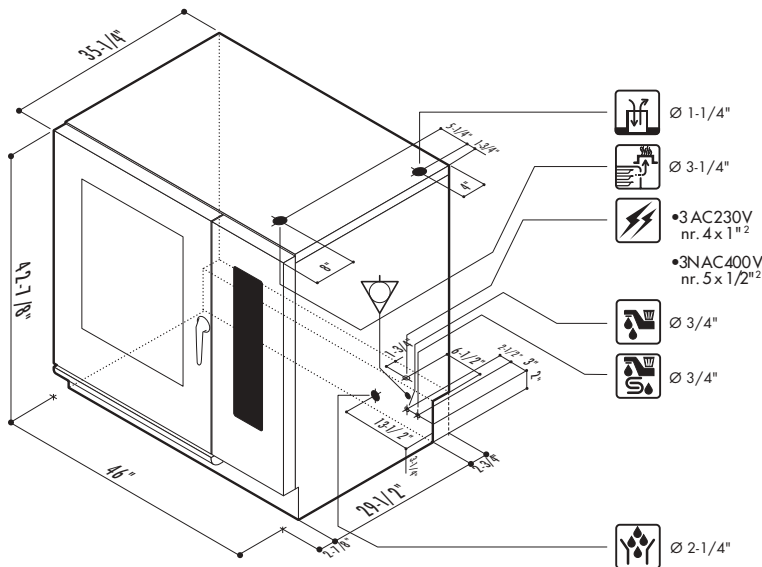

Shipping weight: 645 lbs.

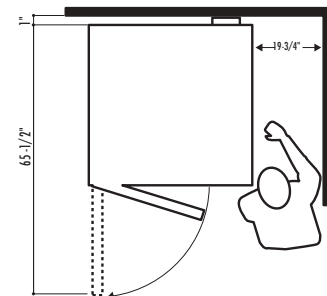
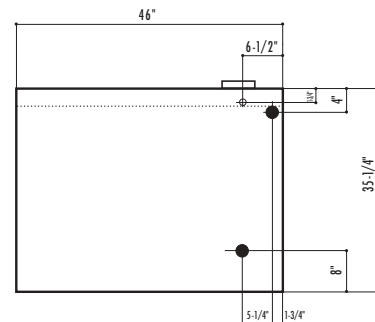

LAINOX – USA

P.O. Box 4129, Winston-Salem, NC 27115
 336/661-0257 • Fax: 336/661-9546
 800/551-8795
 chef@lainox.com; sales@lainox.com

LAINOX – CANADA

P.O. Box 301, Jordan Station, Ontario L0R 1S0
 905/562-4195 • Fax: 905/562-4618
 800/263-5798
 chef@lainox.com; sales@lainox.com

The Mix



www.lainox.com