

ELECTRIC COMBI STEAMER

ME-202T

Multipurpose combi steamer with built-in steam generator for dry heat, steam and combi cooking

CONSTRUCTION DETAILS

- 304 stainless steel construction
- 304 stainless steel cooking compartment with "trapezium" shape, rounded corners for easy cleaning (HACCP requirement) and fully waterproof
- 1- 3/8" rock wool thermal insulation
- Thermal brake between the chamber and oven front panel to absorb steel expansion
- Double glazed door with air interspace keeps outer glass cool
- Hinged inner door glass provides cleaning access
- Slam shut door mechanism adjustable from single to double stage opening
- Adjustable door hinges
- Door opening with progressive brake
- Heat resistant, silicon rubber, push-fit door seal
- Door design includes condensation trough
- Hinged fan baffle cover for cleaning access
- Removable front control panel for easy service of components
- Fully insulated steam generator
- Oven drain with built-in air drop that can be plumbed with a permanent connection and opened for service
- Two water inlets
- Grouped utility connections
- Built-in, retractable hand shower with isolating valve
- External connection for meat probe
- Supplied with stainless steel monoblock trolley with drip tray, 20 levels, and polyurethane wheels with braking mechanism
- High quality components



ELECTRIC HEATING SYSTEM

- Chamber heating elements/INCOLOY 800
- Steam generator heating elements/INCOLOY 800
- Energy saving design

CAPACITY

- 40 hotel pans, 40 half sheet pans or 20 full size sheet pans on rack
- Plated meal rack: 100 plates (12" dia.)

OPERATIONAL FUNCTIONS

- Electronic control panel with Scroller and push-button manual functions; PLUS button for accessing additional features
- Self-diagnosis with fault display and alarm
- Sequential cooking with up to 9 cycles
- Cooking mode selection with display of preset time and temperature
- Store up to 100 recipe programs each with 9 stages and display
- Lainox recipes library
- Low ventilation speed provides reduced heating suitable for slow cooking programs
- Autoreversing fan rotation
- Cook & Hold mode controlled by meat probe or timer
- Multi-point core temperature sensor
- DELTA T cooking mode for increased yield
- Interchangeable meat probes with external socket
- Fast chamber cool down stops at 122°F
- Automatic chamber cooling between a high temperature cycle and a secondary low temperature cycle



VERSION T

Electronic programming with Scroller control, alphanumeric display, AUTOCLIMA, diagnostics, two speed fan, autoreverse (automatic reverse of fan rotation), multi-point core probe, and oven chamber lighting.

COOKING MODES

Convection with AUTOCLIMA 86°F - 572°F
Steam 86°F - 266°F (low temperature, atmospheric, forced)
Combined steam/convection with AUTOCLIMA 86°F - 572°F
Reheating with AUTOCLIMA 248°F - 284°F
Core probe 32°F - 212°F
Automatic sequence cooking
Slow cooking
Cook & Hold with AUTOCLIMA
Three finishing modes
Automatic start delay

- SOFT and HARD cleaning programs (Cube Servicing Program) with detergent injection and rinsing by rotating shower (optional)
- Manual humidifier
- AUTOCLIMA system to control the percentage of humidity during cooking and rethermalization
- Programmable and automatic chamber vent opening to evacuate excess humidity
- Timed halogen oven lights positioned between the door glass
- Automatic boiler preheating
- Connection for an external printer (type RS 232)
- Chamber steam saturation automatically adjusted for energy efficiency
- Boiler descaling program
- Automatic boiler drain and rinse
- Fully automatic drain quenching system
- Programmable 24 hour start delay
- Accessible software parameters for personalized oven presets
- Multiple language display
- Built-in Diagnostic Program:
 - Performance test
 - PC board auto-test

- Preset descaling program
- Displayed diagnostics
- Cube Check System:
 - Checks setting of internal probes
 - Checks chamber and boiler operating hours
 - Indicates time remaining before descaling

SAFETY FEATURES

- Chamber safety thermostat
- Boiler safety thermostat
- Chamber and boiler over pressure release
- Thermal protection of fan motor
- Magnetic door switch
- Boiler water level probes
- Low water alarm
- Component cooling system

DIMENSIONS

- 50-3/4" x 35-1/4" x 76-3/4" (WxDxH)

TECHNICAL DATA

- Voltage: 208-240/60/3
- Total electric power: 61.8 kW

- Hot air power: 60 kW
- Steam power: 60 kW
- Fans power: 1.8 kW

OPTIONS

- Special and marine voltages
- KP202 plated meals trolley
- CP202 Thermal cover
- FX202 Fat filter
- Meat probe (SC); standard or needle type
- LD25 Hand shower

WATER INFORMATION

- Water: cold, potable
- Line pressure:
 - minimum dynamic pressure - 35 psi
 - maximum static pressure - 60 psi
- Chlorine content: 30 ppm
- Inlet connection: 3/4" GPT
- Outlet connection: 2" GPT
- Average water consumption:
 - 16 US gal/hr (13.3 IMP gal/hr)

WATER SOFTENER OR WATER CONDITIONER KIT RECOMMENDED

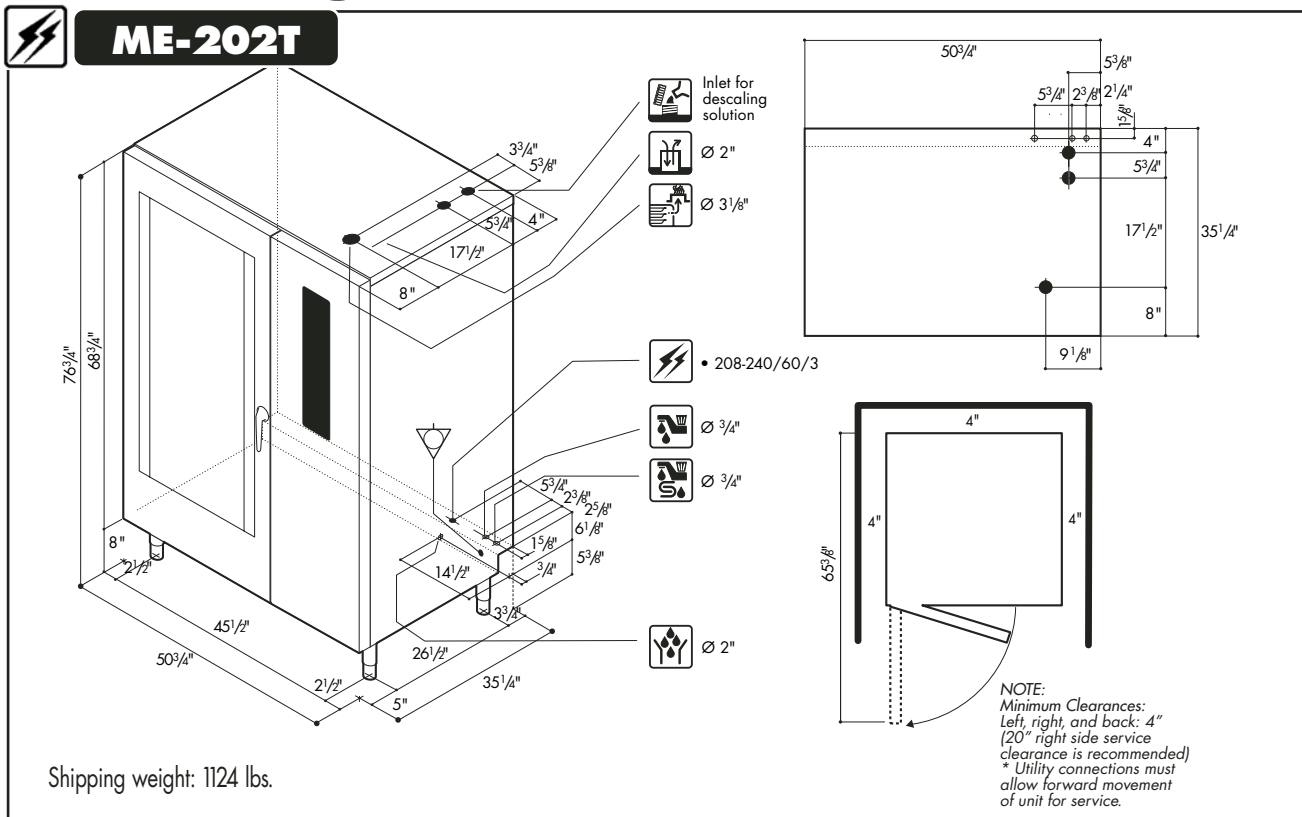

LAINOX - USA

P.O. Box 4129, Winston-Salem, NC 27115
 336/661-0257 • Fax: 336/661-9546
 800/551-8795 • sales@moffat.com

LAINOX - CANADA

P.O. Box 301, Jordan Station, Ontario LOR 1S0
 905/562-4195 • Fax: 905/562-4618
 800/263-5798 • sales@moffat.com

www.lainox.com

